

KAYNAK BOYUNLU LAYNERLİ EKSENEL KOMPANSATÖR

WELD END AXIAL EXPANSION JOINTS WITH INNER SLEEVE

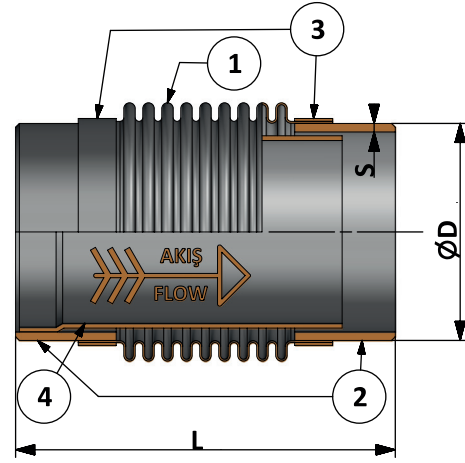

ENL-410



MALZEME ÖZELLİKLERİ MATERIAL SPECIFICATIONS

Parça Tanımı / Part Description	Adet / Pcs.	Malzeme / Material
1. Körük / Bellow	1	1.4301 (AISI 304) - Paslanmaz Çelik / Stainless Steel
2. Çelik Boru Kaynak Boyunlu / Welded Neck Pipe	2	1.0038 (ST.37-2) - Karbon Çelik / Carbon Steel
3. Kaynak Bileziği / Welding Ring	2	1.4301 (AISI 304) - Paslanmaz Çelik / Stainless Steel
4. Layner / Sleeve	1	1.4301 (AISI 304) - Paslanmaz Çelik / Stainless Steel

GENEL ÖZELLİKLER GENERAL SPECIFICATIONS	Tasarım / Design	TS 10880, EN 14917, EJMA
Bağlantı Şekli / Connection Type	Kaynak Boyunlu - Weld End	
Körükler / Bellows	AISI 304 Paslanmaz Çelik - Stainless Steel (Opsiyonel / Optional; AISI 316L/316Ti/321)	
Bağlantı / Connection	St. 37.2 Karbon Çelik - Carbon Steel (Opsiyonel / Optional; AISI 304/316)	
Nominal Çaplar / Nominal Diameter	DN 25 (1") - DN 5000 (200")	
Çalışma Basıncı / Working Pressure	PN16 (Opsiyonel / Optional; PN25, PN40)	
Çalışma Sıcaklığı / Working Temperature	-80/+427°C (Opsiyonel / Optional; -80/+1100°C)	
Uygulamalar / Applications	Sıcak ve soğuk su sistemleri, basınçlı hava, kızgın su, buhar, kızgın buhar, kızgın yağ sistemleri. Hot and cold water systems, compressed air, superheated water, steam, superheated steam systems, superheated oil systems.	

Anma Basıncı / Nominal Pressure		PN16												
Anma Çapı / Nominal Diameter	DN	25	32	40	50	65	80	100	125	150	200	250	300	
ENL-410-30	L 30mm (-20...+10mm)	180	180	190	185	185	185	200	200	245	265	310	310	
ENL-410-60	L 60mm (-40...+20mm)	-	-	-	240	240	245	265	265	315	340	395	395	
ENL-410-30	Eksenel Hareket / Axial Movement	30mm (-20...+10mm)												
ENL-410-60		60mm (-40...+20mm)												
Boyutlar / Dimensions (mm)	ØD	33,7	42,4	48,3	60,3	76,1	88,9	114,3	139,7	165,1	219,1	273	323,9	
	S	3,2	3,2	3,2	3,6	3,6	4	4,5	5	5	6,3	6,3	7,1	